



Type VPR/2/U flow control pressure compensated valves

- 2 ways

Technical specifications and diagrams are measured with mineral oil of 46 cSt viscosity at 40°C (104°F) temperature.

	VPR/2/U 38	VPR/2/U 12	VPR/2/U 34	VPR/2/U 100	
Nominal flow "Qc"	30 l/min (7.9 US gpm)	50 l/min (13.2 US gpm)	90 l/min (23.8 US gpm)	150 l/min (39.6 US gpm)	
Nominal flow "SB"*	15 l/min (4.0 US gpm)	25 l/min (6.6 US gpm)	45 l/min (11.9 US gpm)	75 l/min (19.8 US gpm)	
Max. pressure	Aluminium body = 210 bar (3050 psi) Steel body = 350 bar (5100 psi)				
Fluid	mineral based oil				
Viscosity	from 10 to 200 cSt				
Max. level of contamination	18/16/13 ISO4406				
Fluid temperature	with NBR seals from -20°C (-4°F) to 80°C (176°F) with FPM seals from -20°C (-4°F) to 100°C (212°F)				
Environmental temperature for working conditions	from -40°C (-40°F) to 100°C (212°F)				
Weight	aluminium	0.87 kg (1.91 lb)	0.88 kg (1.94 lb)	1.74 kg (3.84 lb)	3.96 kg (8.73 lb)
	steel	1.92 kg (4.23 lb)	1.99 kg (4.39 lb)	3.56 kg (7.85 lb)	7.80 kg (17.20 lb)

NOTE - For different conditions, please contact Walvoil Sales Dpt.

*"SB" execution (sensibilized adjustment)

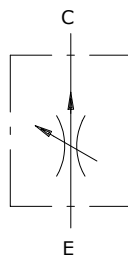

Dimensions

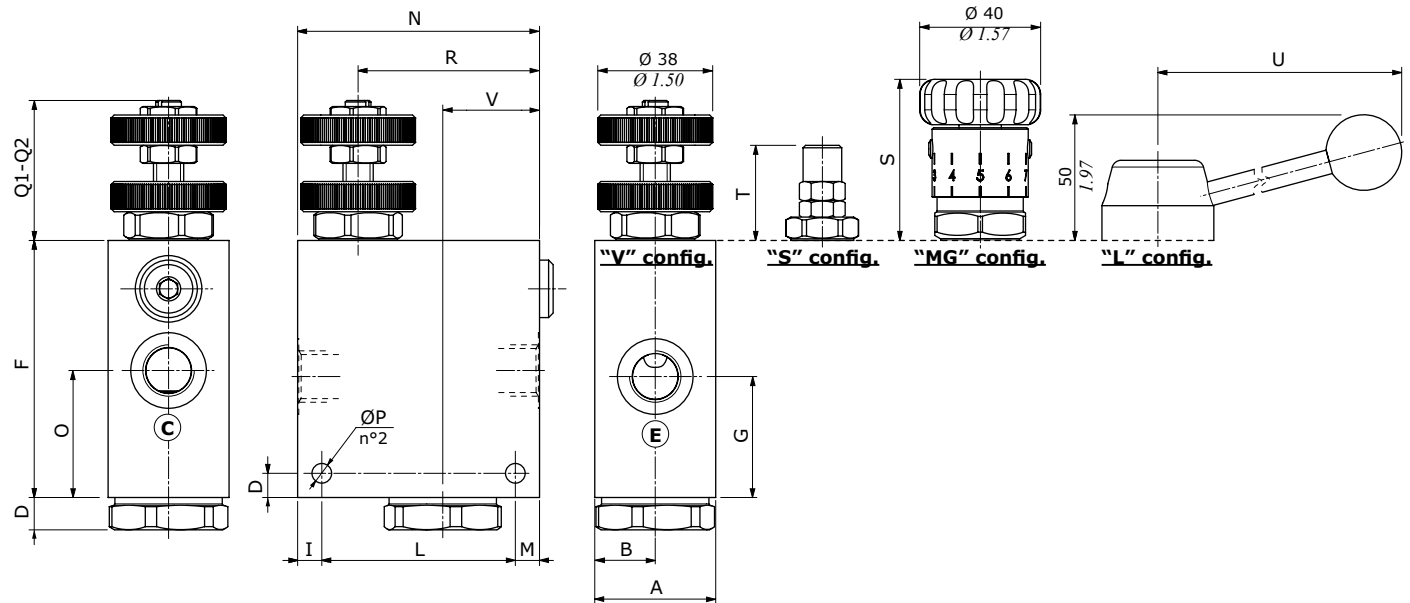

Valve type	All ports	Valve type	All ports
VPR/2/U 38	G3/8	VPR/2/U 38/SAE	SAE8
VPR/2/U 12	G1/2	VPR/2/U 12/SAE	SAE10
VPR/2/U 34	G3/4		
VPR/2/U 100	G1"		

Dimensions are in mm-in

Valve type	A	B	D	F	G	H	I	L	M	N	O	ØP	Q1	Q2*	R	S	T	U	V
VPR/2/U 38	40	20	10.7	85	40	8	8	64	8	80	40.5	6.5	46.3	52.6	60	53.3	38.5	50	103.3
VPR/2/U 38/SAE	1.57	0.78	0.42	3.35	1.57	0.315	0.315	2.51	0.315	3.14	1.59	0.256	1.82	2.07	2.36	2.10	1.51	1.97	3.99
VPR/2/U 12	40	20	10.7	85	40	8	8	64	8	80	42	6.5	46.3	53.1	60	53.3	38.5	50	103.3
VPR/2/U 12/SAE	1.57	0.78	0.42	3.35	1.57	0.315	0.315	2.51	0.315	3.14	1.65	0.256	1.82	2.09	2.36	2.10	1.51	1.97	3.99
VPR/2/U 34	50	25	10.7	100	44	10	8	84	8	100	44	8.5	41.5	50.5	72	56.5	38.5	50	103.3
	1.97	0.98	0.42	3.94	1.73	0.39	0.315	3.31	0.315	3.94	1.73	0.335	1.73	1.99	2.83	2.22	1.51	1.97	3.99
VPR/2/U 100	70	35	13.5	140	58	10	10	100	10	120	58	10.5	52	-	92	56.5	41.5	50	107
	2.75	0.53	0.53	5.51	2.28	0.394	0.394	3.94	0.39	4.72	2.28	0.413	2.05		3.62	2.22	1.63	1.97	4.21

*"SB" execution (sensibilized adjustment)

Flow control valves

Flow control pressure compensated valves

VPR/2/U

Ordering codes and description composition

Port size
VPR/2/U 38/V
1

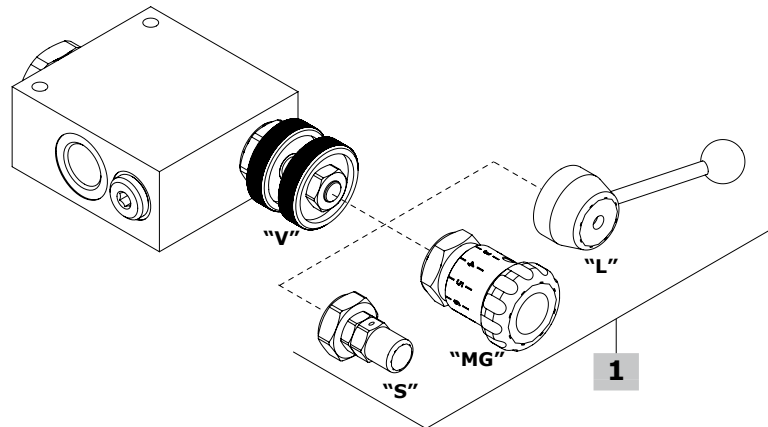

VPR/2/U complete valves

TYPE	CODE	DESCRIPTION
Adjustment kit type "V" (handwheel)		
VPR/2/U 38/V	1613021100	Aluminium body, 3/8 ports
VPR/2/U 12/V	1613031100	Aluminium body, 1/2 ports
VPR/2/U 34/V	1613041100	Aluminium body, 3/4 ports
VPR/2/U 100/V	1613051100	Aluminium body, 1" ports
VPR/2/U 38/V/ac	1613022100	Steel body, 3/8 ports
VPR/2/U 12/V/ac	1613032100	Steel body, 1/2 ports
VPR/2/U 34/V/ac	1613042100	Steel body, 3/4 ports
VPR/2/U 100/V/ac	1613052100	Steel body, 1" ports
VPR/2/U 38/V/SAE	1613021200	Aluminium body, SAE8 ports
VPR/2/U 12/V/SAE	1613031200	Aluminium body, SAE10 ports

Adjustment kit type "MG" (handknob)

VPR/2/U 38/MG	1613021101	Aluminium body, 3/8 ports
VPR/2/U 12/MG	1613031101	Aluminium body, 1/2 port
VPR/2/U 34/MG	1613041101	Aluminium body, 3/4 ports
VPR/2/RL 100/MG	1613051101	Aluminium body, 1" ports
VPR/2/U 12/MG/SAE	1613031201	Aluminium body, SAE10 port
VPR/2/RL 100/MG/SAE	1613051200	Aluminium body, SAE16 ports

Adjustment kit type "L" (lever)

VPR/2/U 38/L	1613021102	Aluminium body, 3/8 ports
VPR/2/U 12/L	1613031102	Aluminium body, 1/2 ports
VPR/2/U 34/L	1613041102	Aluminium body, 3/4 ports
VPR/2/U 100/L	1613051102	Aluminium body, 1" ports

For other steel body configurations, SAE thread and configurations with FPM (Viton) seals, please contact our Sales Dpt.

1 Adjustment kit

TYPE	CODE	DESCRIPTION
For VPR/2/RL 38 valve		
V.SB	5KT6200200	"V" handwheel type in "SB" configuration (sensibilized adjustment)
V	5KT6130200	"V" handwheel type
MG	5KT6200202	"MG" handknob type
S	5KT6200211	"S" screw type
For VPR/2/RL 12 valve		
V.SB	5KT6130301	"V" handwheel type in "SB" configuration (sensibilized adjustment)
V	5KT6130200	"V" handwheel type
MG	5KT6200202	"MG" handknob type
S	5KT6200211	"S" screw type
For VPR/2/RL 34 valve		
V	5KT6130401	"V" handwheel type
MG	5KT6200400	"MG" handknob type
S	5KT6130404	"S" screw type
V.SB	5KT6130402	"V" handwheel type in "SB" configuration (sensibilized adjustment)
For VPR/2/RL 100 valve		
V	5KT6340603	"V" handwheel type
MG	5KT6200605	"MG" handknob type
S	5KT6200604	"S" screw type

Rating diagrams

